



INSTRUCTION MANUAL

DSC CONTROLLER  
**DS-100**

---

---

---

Icom Inc.

---

---

## FOREWORD

---

Thank you for purchasing this Icom product. The DS-100 DSC CONTROLLER is designed and built with Icom's superior technology and craftsmanship. With proper care this product should provide you with years of trouble-free operation.

---

## IMPORTANT

---

**READ ALL INSTRUCTIONS** carefully and completely before using the controller.

**SAVE THIS INSTRUCTION MANUAL**—This instruction manual contains important operating instructions for the DS-100.

---

## EXPLICIT DEFINITIONS

---

WORD	DEFINITION
 <b>WARNING</b>	Personal injury, fire hazard or electric shock may occur.
<b>CAUTION</b>	Equipment damage may occur.
<b>NOTE</b>	If disregarded, inconvenience only. No risk of personal injury, fire or electric shock.

---

## FEATURES

---



### **Class D DSC terminal**

The DS-100 VHF DSC CONTROLLER is designed as a 'Class D DSC terminal unit' for the IC-M501EURO VHF MARINE TRANSCEIVER.



### **Self ID indication**

**THE MMSI NUMBER SHOULD BE PROGRAMMED BY A DEALER PRIOR TO INSTALLATION.**

The DS-100 does not function when there is no ID is programmed. Therefore, the ID code should be checked in the Set-up menu.

---

## CAUTIONS

---

**⚠ WARNING! NEVER** connect the controller to an AC outlet. This may pose a fire hazard or result in an electric shock.

**⚠ WARNING NEVER** transmit a distress call when your vessel does not need immediate help. Distress calls can be used only in times of emergency.

**NEVER** connect the controller to a power source of more than 16 V DC. Such a connection will ruin the controller.

**NEVER** place the controller where normal operation of the ship may be hindered or where it could cause bodily injury.

**CE** CE Versions of the DS-100 which display the “CE” symbol on the serial number seal, comply with the essential requirements of the European Radio and Telecommunication Terminal Directive 1999/5/EC.

**AVOID** using or placing the controller in direct sunlight or in areas with temperatures below  $-20^{\circ}\text{C}$  ( $-4^{\circ}\text{F}$ ) or above  $+60^{\circ}\text{C}$  ( $+140^{\circ}\text{F}$ ).

**KEEP** the controller out of the reach of children.

**KEEP** the antenna cable and DC power cable as far away as possible from electrical pumps, generators and other electronic instruments to prevent instrument malfunctions.

**KEEP** the controller and microphone at least 1 meter away from your vessel's magnetic navigation compass.

**DO NOT** use chemical agents such as benzene or alcohol when cleaning, as they can damage the terminal unit surfaces.



This warning symbol indicates that this equipment operates in non-harmonised frequency bands and/or may be subject to licensing conditions in the country of use. Be sure to check that you have the correct version of this radio, or the correct programming for this radio, to comply with national licensing requirements.

---

# TABLE OF CONTENTS

---

FOREWORD .....	i	■ Offset time .....	19
IMPORTANT .....	i	■ Brightness .....	19
EXPLICIT DEFINITIONS .....	i	■ Contrast .....	19
FEATURES .....	i	■ MMSI check .....	19
WARNING .....	i	<b>5 CONNECTIONS AND INSTALLATIONS .....</b>	<b>20–22</b>
CAUTIONS .....	ii	■ Connection diagram .....	20
TABLE OF CONTENTS .....	iii	■ Rear panel description .....	21
<b>1 PANEL DESCRIPTION .....</b>	<b>1-2</b>	■ Supplied accessories .....	21
■ Front panel .....	1	■ Mounting .....	22
■ Function display .....	2	<b>6 VHF MARINE CHANNEL LIST .....</b>	<b>23</b>
<b>2 CALL PROCEDURE .....</b>	<b>3–8</b>	<b>7 SPECIFICATIONS AND OPTIONS .....</b>	<b>24</b>
■ Distress call/Simple operation .....	3	■ Specifications .....	24
■ Distress call/Regular operation .....	4	■ Options .....	24
■ Entry Position/Time .....	5	<b>8 DIMENSIONS .....</b>	<b>25</b>
■ Distress call to ship .....	6	<b>9 MB-75 (OPTION) .....</b>	<b>26-27</b>
■ Individual call .....	6	■ MB-75 FLUSH MOUNT KIT .....	26
■ Group call .....	7		
■ ALL ships call .....	7	<b>TEMPLATE</b>	
<b>3 WHEN RECEIVING A DISTRESS CALL .....</b>	<b>9–17</b>	<b>DOC</b>	
■ When receive a distress call .....	9		
■ Received message .....	13		
<b>4 SET-UP .....</b>	<b>17–19</b>		
■ Select 'Set-up' .....	17		
■ Address ID .....	17		

## ■ Front panel

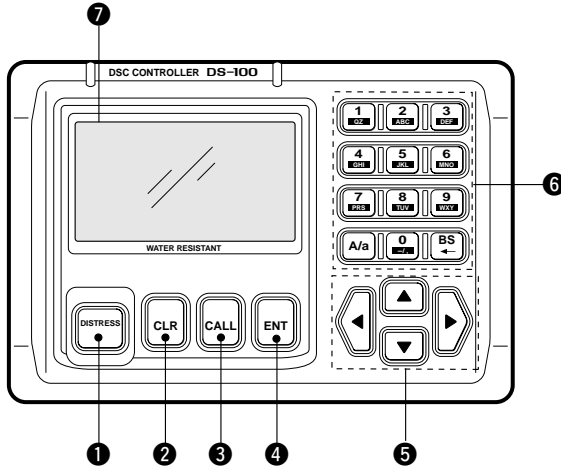

### ① DISTRESS BUTTON

Push and hold for 5 sec. to make a distress call.

### ② CLEAR SWITCH [CLR]

- ➔ Push this key to cancel Call repeat.
- ➔ Push this key to cancel the menu.

### ③ CALL SWITCH [CALL]

- ➔ Push this key to call subject menu screen.
- ➔ Push the key to return the start screen.

### ④ ENTER [ENT]

- ➔ Enters the selected subject and advances the item to indicate the contents.
- ➔ Push this key to determine the data.

### ⑤ UP/DOWN/LEFT/RIGHT SWITCHES [▲]/[▼]/[◀]/[▶]

- ➔ Push [▲]/[▼] to select the menu contents in the selected item.
- ➔ Push [▲]/[▼] to adjust brightness and contrast.
- ➔ Push [◀]/[▶] to move the cursor position.

### ⑥ KEYPAD

- ➔ Input the corresponding number or letters when required.
- ➔ Other functions are as follows;
  - [A/a]—Push this key to toggle the capital letter, small letter or numerals. 'A; capital letter' or 'a; small letter' appears in the upper right of the display, depending on selection.
  - [BS]—Backspace key.

### ⑦ FUNCTION DISPLAY

During normal operation the display shows position and UTC (or Local) time when a GPS receiver is connected. This is updated each time new GPS data is received.

If no GPS receiver is connected, the position and UTC time must be set in advance.

# 1 PANEL DESCRIPTION

**NOTE:** If GPS data is interrupted for 30 sec. the “GPS” indication disappears. The terminal unit retains the most recent data in such cases.

## ■ Function display

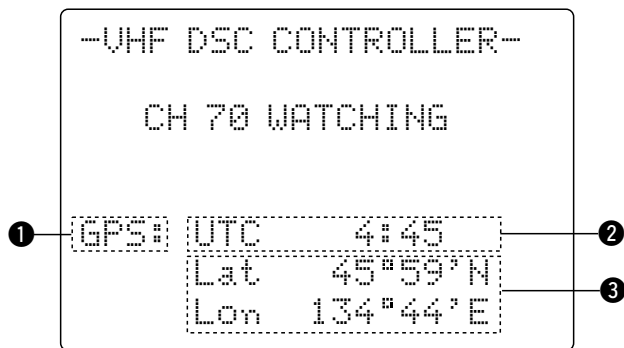

### ① GPS INDICATOR

- ↳ “GPS” appears while GPS receiver is connected.
- ↳ “GPS” disappears when no GPS receiver is connected.
- ↳ “MNL” appears when the time data and position data are input manually.

### ② TIME ZONE INDICATOR

- ↳ “Local” appears when the offset time data on the ‘Set-up’ menu is entered.
- ↳ “No time data” appears when no GPS receiver is connected and no time data is input manually.

### ③ POSITION INDICATOR

- ↳ Shows the GPS position data.
  - “??” may blink every 2 sec. instead of position data, when the GPS position data is invalid. In such a case, the last position data is held up to 23.5 hours.
- ↳ Shows the manually input position data when no GPS receiver is connected. “MNL” appears instead of “GPS” at ①.
  - “??” may blink every 2 sec. instead of position data, 4 hours after the position data is input manually up until 23.5 hours have past.
- ↳ “No position data” appears when no GPS receiver is connected and no position data is input manually.

## ■ Distress call/simple operation

A distress call should be transmitted if, in the opinion of the Master, the ship or a person is in distress and requires immediate assistance.

A distress call should include the ship's position and time. They are included automatically when a GPS receiver is connected. If no GPS is connected, input them, if possible.

**NEVER: USE THE DISTRESS CALL WHEN YOUR SHIP IS NOT IN AN EMERGENCY. DISTRESS CALL CAN BE USED ONLY WHEN IMMEDIATE HELP IS NEEDED.**

- ① Confirm any distress call is not being received.
- ② Lift up the switch cover, pushing and holding the [DISTRESS] button for 5 sec. to transmit the distress call.
  - A DSC channel (ch 70) is automatically selected and the distress call is transmitted.
  - If you have the time, select the nature of the distress and contents.
  - If no GPS is connected, your location and UTC time should be input.

<Push and hold  
[DISTRESS] for 5 sec>

Nature of distress:  
Undesignated  
GPS : UTC 15:22  
12°34' N  
123°45' W

- ③ After transmitting the call, the transceiver is set to the phone frequency (ch 16) automatically.
  - The controller is still waiting on ch 70 for an acknowledgment call.
- ④ When receiving the acknowledgment, reply to the connected station via the transceiver's microphone as described on page 8.

Distress alert  
Completed

Now waiting for  
acknowledgment

<CLR>Exit>

### NOTE:

- Distress alert (simple operation) contains (default);
  - Kinds of distress: Undesignated distress
  - Position data: According to the displayed information.
  - GPS or manual input position data held for 23.5 hrs.
- Distress call repeats every 3.5–4.5 min., until receiving an 'acknowledgement'
- Beep (Pi,Pi) sounds with the max. volume every 1 sec.
- Push [DISTRESS] button to transmit a renewed distress call, if desired.
- Push [CLR] to cancel the 'Call repeat' mode.
  - The 'cancel acknowledgement' is automatically transmitted when the [CLR] key is pushed.

## 2 CALL PROCEDURE

### ■ Distress call/Regular operation

Transmit a distress call after selecting the 'Distress setting'.

**NEVER: USE THE DISTRESS CALL WHEN YOUR SHIP IS NOT IN AN EMERGENCY. DISTRESS CALL CAN BE USED ONLY WHEN IMMEDIATE HELP IS NEEDED.**

- ① Push [CALL], then push [▼] several times to select 'Distress setting'.
- ② Push [ENT] to select <Select a nature>. Push [▼] several times to select the desired nature, then push [ENT].
  - Push [CLR] to Exit the menu.
- ③ Confirm the location data, then push [ENT] to confirm the time data.
- ④ Confirm the UTC time, then push [ENT] to confirm the time data.
  - If no GPS is connected, your location and UTC time should be input.

<Select a subject>

Entry position/time  
Individual call  
Group call  
All ships call  
Received calls  
▶Distress setting

- ⑤ Lift up the [DISTRESS] switch cover, pushing and holding the button for 5 sec. to transmit the distress call.
  - A DSC channel (ch 70) is automatically selected and the distress call is transmitted.
  - If no GPS is connected, your location and UTC time should be input.
- ⑥ After transmitting the call, the transceiver is set to the **voice calling channel** (ch 16) automatically.
  - The controller is still waiting for an acknowledgment call on ch 70.
- ⑦ When receiving the acknowledgment, reply to the connected station via the transceiver's microphone as described [on page 8](#).

<Select a nature>

Undesignated  
Fire, Explosion  
Flooding  
Collision  
Grounding  
Capsizing  
▶Sinking  
Disable drift  
Abandoning ship  
Piracy attack  
Man overboard  
EPIRB emission

<Push and hold  
[DISTRESS] for 5 sec>

Nature of distress:  
Abandoning ship  
GPS : UTC 15:22  
12.34' N  
123.45' W



**NOTE:**

- 'nature of distress' will be valid for 10 min. until a distress call transmits. After 10 min. it reverts to an undesignated distress.
- Distress call repeats every 3.5–4.5 min., until receiving an 'acknowledgement'
- Beep (Pi,Pi) sounds with the max. volume every 1 sec. until acknowledgement is received.
- Push clear to cancel a distress call prior to receiving an acknowledgement.

The 'cancel acknowledgement' is automatically transmitted when the [CLR] key is pushed.

## ■ Entry Position/Time

When no GPS receiver is connected, the 'Entry Position/Time' appears at the top of subject menu.

- ① Push [CALL], then push [▼] to select 'Entry Position/Time'.
- ② Push [ENT], then enter the latitude data with key pad.
- ③ Push [▲]/[▼] to select N; north latitude or S; south latitude, then push [ENT].
  - Push [◀]/[▶] to move the cursor then push [▲]/[▼] to correct the data
  - Push [CLR] to Exit the menu.
  - Push [A/a], the push [ENT] to enter a 'Null data'.
- ④ Enter the longitude data with key pad.
- ⑤ Push [▲]/[▼] to select E; east longitude or W; west longitude, then push [ENT].
  - Push [◀]/[▶] to move the cursor then push [▲]/[▼] to correct the data
  - Push [CLR] to Exit the menu.
  - Push [A/a], the push [ENT] to enter a 'Null data'.

```

<Input a position>

Latitude
  _____ ° ' N
Longitude
  _____ ° ' E
<A/a→Null data>
<CLR→Exit / ENT→OK>
  
```

```

<Input a Time>

UTC ____ : ____

<A/a→Null data>
<CLR→Exit / ENT→OK>
  
```

## 2 CALL PROCEDURE

### ⑥ Push UTC time with keypad.

- Push [◀]/[▶] to move the cursor then push [▲]/[▼] to correct the data
- Push [CLR] to Exit the menu.
- Push [A/a], then push [ENT] to enter 'Null data'.

## ■ Distress call to ships

General DSC calls may be used for communications after the Distress call, e.g. you want to change the operating mode, frequency, etc.

## ■ Individual call

- ① Push [CALL], then push [▼] several times to select 'Individual call' then push [ENT].
- ② Push manual entry to enter 9 digit ID or push [▼] to select the desired address. Then push [ENT].  
(See page 17 for adding an address.)
- ③ Select your desired traffic channel.
- ④ To select desired traffic channel, push [BS] twice and enter channel number.\*
- ⑤ Push [CALL] and [ENT] simultaneously to transmit an Individual call.
- ⑥ Push [CLR] to stop the call.

<Select an address ID>

▶Manual entry  
DS-100 SN10  
DS100 SN2  
DS100 SN3

<CLR→Exit / ENT→OK>

<Input an address>

ID: (9di gi t)

<CLR→Exit / ENT→OK>

\* Traffic channel automatically defaults to channel 16.

## ■ Group call

- ① Push [CALL], then push [▼] one or more times to select 'Group call', then push [ENT].
- ② Select the desired address, then push [ENT].
  - Enter the 8 digit address when 'Manual entry' is selected.
- ③ To select desired traffic channel push [BS] twice and enter channel number.\*
- ④ Push [CALL] and [ENT] simultaneously to transmit a 'Group call'.
- ⑤ Push [CLR] to stop the call.

\* Traffic channel automatically defaults to channel 16.

```
<Select a group>
▶Manual entry
  I COM
<CLR→Exit / ENT→OK>
```

```
<Input an address>
ID: (8di gi t)
   0_____
<CLR→Exit / ENT→OK>
```

## ■ All ships call

- ① Push [CALL], then push [▼] one or more times to select 'All ships call', then push [ENT].
- ② Select the desired category, then push [ENT].
- ③ To select desired traffic channel push [BS] twice and enter channel number.\*
- ④ Push [CALL] and [ENT] simultaneously to transmit an All ships call.
- ⑤ Push [CLR] to stop the call.

\* Traffic channel automatically defaults to channel 16.

```
<Select a category>
Safety
▶Urgency
<CLR→Exit / ENT→OK>
```

---

## 2 CALL PROCEDURE

### ◇ When no acknowledgement is received

When no acknowledgement is received the unit will beep every one second. In this case, the controller automatically transmits the distress call again every 3.5 to 4.5 minutes.

- A distress relay call may be received after several minutes from another ship if acknowledgement cannot be received from a coast station directly.

 **CAUTION: DO NOT** push [CLR] while waiting for an acknowledgement, otherwise the distress call repeat will be canceled, and a distress acknowledgement is automatically transmitted with your own MMSI. Use the [CLR] key only when you want to cancel repeated transmission.

### ◇ After receiving acknowledgement call

The following should be commenced with your voice transmission after receiving a distress acknowledgement from a coast station (or another ship).

- “MAY DAY”
- “This is .....(your ship name)”
- The 9-digit identity AND the call sign (or other identification of the ship).
- The ship’s position if the DSC distress does not include it.
- The nature of the distress and assistance required.
- Any other information which might facilitate the rescue.

## ■ When receiving a Distress call

### ◇ When receiving a Distress call

When receiving a distress call, an alarm (Pi-po) sounds with max. AF level continuously. And at the same time, the transceiver's (IC-M501EURO) operating channel changes to CH 16 automatically.

–RCV Di stress call–

Distress ID:  
23456789  
Distress time & pos  
Time: UTC 12:34  
Pos.: Lat 12°34' N  
Lon 123°45' W

- Push [CLR] to cancel the alarm.
- Monitor the communication between the calling ship and a coast station. When no communication is made, contact the ship using voice transmission on CH 16.

### 3 WHEN RECEIVING A DSC CALL

#### ◇ When receiving an individual call

When receiving an individual call, an alarm (Pi-pi) sounds.

- Push [ENT], then the operating channel changes to designated channel.
- Push [CLR] to record the received information, then the screen goes back to default.
- The calling station transmits via voice on the designated channel.

–RCV Individual call–

From: JHON

<CLR→Exit/ ENT→OK>

#### • When the individual ACK function is available

When the individual acknowledgement function\* is available on your controller, push [ENT] to turn to the <Select to comply> screen.

- Select 'Able to comply' or 'Unable to comply'.
- Emergency alarm (or continuous beeps depending on the category) sounds until pushing [CLR].

<Select to comply>

▶Able to comply  
Unable to comply

<CLR→Exit/ ENT→OK>

◇ **When receiving an All ships call**

- When receiving a Routine or Safety all ships call, an alarm (Pi-pi) sounds.
- When you receive a distress or Urgency all ships call, an alarm (Pi-po) sounds with max. AF level continuously.
  - Push [CLR] to cancel the alarm.
  - Push [ENT], then the operating channel changes to received traffic channel automatically.
  - Push [CLR] to record the received information, then the screen goes back to default.

```

-RCV All ships call-
From: 23456789
Category: Routine

<CLR→Exit/ ENT→OK>
    
```

You must monitor the traffic frequency until you can judge from the call that your action has been effective and/or assistance is unnecessary.

◇ **When receiving a Position request**

When receiving a Position request call, an alarm (Pi-pi) sounds.

- Push [ENT] to transmit your own ships longitude and latitude information.
- Push [CLR] to record the received information, then the screen goes back to default.

```

-RCV Pos request-
From: JHON

To reply, push ENT
<CLR→Exit/ ENT→OK>
    
```

◇ **When receiving a Position reply**

When receiving a Position reply, an alarm (Pi-pi) sounds.

- Push [CLR] to record the received information, then the screen goes back to default.

```

-RCV Pos reply-
From: Beck

Pos. : Lat 12°34' N
      Lon 123°45' W
<CLR→Exit>
    
```

### 3 WHEN RECEIVING A DSC CALL

#### ◇ When receiving a Distress ACK

When receiving a distress acknowledgement, an alarm (Pi-po) sounds with max. AF level continuously. And at the same time, the transceiver's (IC-M501EURO) operating channel changes to CH 16 automatically.

- Push [CLR] to cancel the alarm.
- You must monitor CH 16 until you can judge from the call that your assistance is unnecessary.

–RCV Di stress ACK–

From: Tokyo guard  
Di stress ID:  
Mr. Bean

<CLR→Exi t/ ENT→OK>

#### ◇ When receiving a Distress Relay ACK

When receiving a Distress Relay acknowledgement, an alarm (Pi-po) sounds with max. AF level continuously. And at the same time, the transceiver's (IC-M501EURO) operating channel changes to CH 16 automatically.

- Push [CLR] to cancel the alarm.
- You must monitor CH 16 until you can judge from the call that your assistance is unnecessary.

–RCV Di stress RLY ACK–

From: Tokyo guard  
Di stress ID:  
987654321

<CLR→Exi t/ ENT→OK>

#### ◇ When receiving a group call

When receiving a Group call, an alarm (Pi-pi) sounds.

- Push [ENT], then the operating channel changes to designated channel.
- Push [CLR] to record the received information, then the screen goes back to default.
- The calling station transmits via voice on the designated channel.

–RCV Group call–

From: DS-100 SN3  
Group: I com I nc

<CLR→Exi t/ ENT→OK>



## ■ Received message (RCV MSG)

When receiving a DSC call, the received format is specified and its contents are memorized into the received message (RCV MSG) memory. Distress calls (including other calls with distress category) are stored separately from other calls.

Up to 20 distress calls can be memorized and up to 20 other categories of calls can be memorized. However, the distress calls are saved until being erased, while other calls are erased when the power is turned OFF.

```
<Select a subject>
Entry Position/Time
Individual call
Group call
All ships call
▶Received calls
Distress setting
```

## ◇ Distress message

- ① Push [CALL], then push [▼] one or more times to select 'Received calls', then push [ENT].
- ② Select a 'Distress message', then push [ENT].
- ③ Select a desired message, then push [ENT].
  - Push [▲] or [▼] to scroll the message.
  - Push [A/a], then push [1] to clear the message.

```
<Select a message>
▶Distress message
Other message

<CLR>Exit / ENT→OK>
```

```
<Select a message>
▶1: Distress 12: 21
2: Distress 11: 21
3: Distress 10: 21
4: Distress 09: 21

<CLR>Exit / ENT→OK>
```

```
<Message contents>
Distress ID:
2345678
Piracy attack
Distress time & Pos
Time: UTC 12: 34
Pos.: Lat 12° 34' N
Lon 123° 45' W

<A/a>Data clear>
```

### 3 WHEN RECEIVING A DSC CALL

#### ◇ Other messages

##### • Individual call

- ① Push [CALL], then push [▼] several times to select 'Received calls', then push [ENT].
- ② Select 'Other message', then push [ENT].
- ③ Select 'Individual call', then push [ENT].
  - Push [▲] or [▼] to scroll the message.
  - Push [A/a] to clear the message.

<Select a message>

1: Individual ACK  
▶2: Individual call  
3: Group call  
4: All ships call  
5: Distress  
6: Distress relay  
7: Distress RLY ACK  
8: Distress ACK

<CLR→Exit / ENT→OK>

<Message contents>

Routine to Individual  
From: DS-100 SN3  
F3E/G3E simplex  
CH88  
No information

<A/a→Data clear>

##### • Group call

- ① Push [CALL], then push [▼] several times to select 'Received calls', then push [ENT].
- ② Select 'Other message', then push [ENT].
- ③ Select 'Group call', then push [ENT].
  - Push [▲] or [▼] to scroll the message.
  - Push [A/a] to clear the message.

<Select a message>

1: Individual ACK  
2: Individual call  
▶3: Group call  
4: All ships call  
5: Distress  
6: Distress relay  
7: Distress RLY ACK  
8: Distress ACK

<CLR→Exit / ENT→OK>

<Message contents>

Routine to group  
From: Phil Collins  
F3E/G3E simplex  
CH78  
No information

**• All ships**

- ① Push [CALL], then push [▼] several times to select 'Received calls', then push [ENT].
- ② Select 'Other message', then push [ENT].
- ③ Select 'All ships call', then push [ENT].
  - Push [▲] or [▼] to scroll the message.
  - Push [A/a] to clear the message.

<Message contents>

Urgency to All ships  
From: DS-100 SN3  
F3E/G3E simplex  
CH 14

<A/a→Data clear>

**• Distress relay**

- ① Push [CALL], then push [▼] several times to select 'Received calls', then push [ENT].
- ② Select 'Other message', then push [ENT].
- ③ Select 'Distress relay', then push [ENT].
  - Push [▲] or [▼] to scroll the message.
  - Push [A/a] to clear the message.

<Message contents>

Distress relay  
From: Phil Collins  
Distress ID:  
2345678  
To all ships  
Fire, Explosion  
Distress Time & Pos  
Time: UTC 12:34  
Pos.: Lat 12°34' N  
Lon 123°45' W

<A/a→Data clear>

**• Distress**

- ① Push [CALL], then push [▼] several times to select 'Received calls', then push [ENT].
- ② Select 'Other message', then push [ENT].
- ③ Select 'Distress', then push [ENT].
  - Push [▲] or [▼] to scroll the message.
  - Push [A/a] to clear the message.

<Message contents>

Routine to group  
From: Phil Collins  
F3E/G3E Simplex  
CH88  
No Information

<A/a→Data clear>

### 3 WHEN RECEIVING A DSC CALL

#### • Distress relay acknowledgement

- ① Push [CALL], then push [▼] several times to select 'Received calls', then push [ENT].
- ② Select 'Other message', then push [ENT].
- ③ Select 'Distress RLY ACK', then push [ENT].
  - Push [▲] or [▼] to scroll the message.
  - Push [A/a] to clear the message.

<Select a message>

1: I n d i v i d u a l   A C K  
2: I n d i v i d u a l   c a l l  
3: G r o u p   c a l l  
4: A l l   s h i p s   c a l l  
5: D i s t r e s s  
6: D i s t r e s s   r e l a y  
▶7: D i s t r e s s   R L Y   A C K  
8: D i s t r e s s   A C K

<CLR→Exit / ENT→OK>

#### \* Please note:

Commercial vessels can only transmit distress relay messages.

<Message contents>

D i s t r e s s   R L Y   A C K  
F r o m :   M r .   C o m f o r t  
D i s t r e s s   I D :  
    M r s .   J o h n  
F i r e ,   E x p l o s i o n  
D i s t r e s s   T i m e   &   P o s  
T i m e :   U T C      1 2 :   3 4  
P o s . :   L a t   1 2 ° 3 4 '   N  
            L o n   1 2 3 ° 4 5 '   W

<A/a→Data clear>

#### • Distress acknowledgement

- ① Push [CALL], then push [▼] several times to select 'Received calls', then push [ENT].
- ② Select 'Other message', then push [ENT].
- ③ Select 'Distress ACK', then push [ENT].
  - Push [▲] or [▼] to scroll the message.
  - Push [A/a] to clear the message.

<Select a message>

1: I n d i v i d u a l   A C K  
2: I n d i v i d u a l   c a l l  
3: G r o u p   c a l l  
4: A l l   s h i p s   c a l l  
5: D i s t r e s s  
6: D i s t r e s s   r e l a y  
7: D i s t r e s s   R L Y   A C K  
▶8: D i s t r e s s   A C K

<CLR→Exit / ENT→OK>

<Message contents>

D i s t r e s s   A C K  
F r o m :   M r .   F o r t u n e  
D i s t r e s s   I D :  
    M r s .   J o h n  
F i r e ,   E x p l o s i o n  
D i s t r e s s   T i m e   &   P o s  
T i m e :   U T C      1 2 :   3 4  
P o s . :   L a t   1 2 ° 3 4 '   N  
            L o n   1 2 3 ° 4 5 '   W

<A/a→Data clear>

## ■ Select 'Set-up'

The following setting/operations available in 'Set-up' menu.

- Address ID
- Offset time
- Brightness
- Contrast
- MMSI check

- ① Push [CALL], then push [▼] several times to select 'Set-up', then push [ENT].
  - 'Set-up' menu appears on the screen.
- ② Push [CLR] to exit the Set-up menu.

<Select a subject>

Individual ACK  
Group call  
All ships call  
Received calls  
Distress setting  
▶Set-up

<Select a subject>

▶Address ID  
Offset time  
Brightness  
Contrast  
MMSI CHECK

<CLR→Exit / ENT→OK>

## ■ Address ID

A total of 70 address ID can be programmed as "Address ID" (for ships and coast stations) and "Group ID" (for group station).

### • Add an address ID

- ① Push [▲]/[▼] several times to select 'Add an address ID', then push [ENT].
- ② Push numeral keys to input an address ID code, then push [ENT].
  - When a wrong number is input, push [CLR], then correct the number again.
- ③ Enter the desired name for the ID code, then push [ENT].
  - Push [A/a] several times to toggle capital letters, small letters and numerals.
  - Push the corresponding key one or more times to input the desired character.
  - Push [BS] to erase the character.
  - Push [◀] to reverse the cursor position; [▶] to forward the cursor position.
- ④ Push [CLR] to exit the screen.

<Select a subject>

▶Add an address ID  
Delete address ID  
Add a group ID  
Delete a group ID

<CLR→Exit / ENT→OK>

<Add an address ID>a\*

ID: (9digit)

Name: (15characters)

<CLR→Exit / ENT→OK>

## 4 SET-UP

### • Delete address ID

- ① Push [▼] to select 'Delete address ID', then push [ENT].
- ② Push [▲]/[▼] several times to select a desired address ID that you want to delete, then push [ENT].
  - Address ID and name is displayed on the screen.
- ③ Push [ENT] to delete the address ID.
  - Push [CLR] to exit the screen.
- ④ Push [CLR] to exit the menu.

<Delete address ID>

▶DS-100 SN10  
DS-100 SN2  
DS-100 SN3  
DS-100 SN4

<CLR→Exit / ENT→OK>

<Delete this ID>

ID: (9digits)  
2673500100  
Name: (15characters)  
DS-100 SN10

<CLR→Exit / ENT→OK>

### • Add a group ID

- ① Push [▲]/[▼] several times to select 'Add a group ID', then push [ENT].
- ② Push numeral keys to input an address ID code, then push [ENT].
  - When a wrong number is input, push [CLR], then correct the number again.
- ③ Enter the desired name for the ID code, then push [ENT].
  - Push [A/a] several times to toggle capital letters, small letters and numerals.
  - Push the corresponding key one or more times to input the desired character.
  - Push [BS] to erase the character.
  - Push [◀] to reverse the cursor position; [▶] or forward the cursor position.
- ④ Push [CLR] to exit the screen.

<Add a group ID> a\*

ID: (8digits)  
0\_\_\_\_\_  
Name: (15characters)

<CLR→Exit / ENT→OK>

### • Delete a group ID

- ① Push [▼] to select 'Delete a group ID', then push [ENT].
- ② Push [▲]/[▼] several times to select a desired address ID that you want to delete, then push [ENT].
  - Address ID and name is displayed on the screen.
- ③ Push [ENT] to delete the address ID.
  - Push [CLR] to exit the screen.
- ④ Push [CLR] to exit the menu.

## ■ Offset time

Local time can be used when the GPS position data is valid and off set time is input.

- ① Push [CALL], then push [▼] one or more times to select 'Set-up', then push [ENT].
- ② Select 'Offset time', then push [ENT].
- ③ Push "0; -" or "1; space", then input the time differences.
- ④ Push [ENT] to determine the time or push [CLR] to exit the Set-up menu.

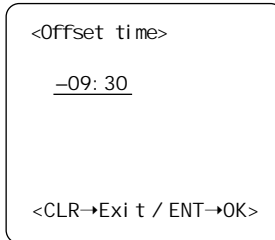

## ■ Brightness

### • Adjusting the brightness

- ① Push [CALL], then push [▼] one or more times to select 'Set-up', then push [ENT].
- ② Select 'Brightness', then push [ENT].
- ③ Push [▲] or [▼] one or more times (or numeral keys instead) to adjust the brightness.
  - Brightness level indication; 1 (dark) to 8 (bright)
- ④ Push [ENT] to determine the brightness or push [CLR] to exit the Set-up menu.

## ■ Contrast

### • Adjusting the contrast

- ① Push [CALL], then push [▼] one or more times to select 'Set-up', then push [ENT].
- ② Select 'Contrast', then push [ENT].
- ③ Push [▲] or [▼] one or more times (or numeral keys instead) to adjust the contrast.
  - Contrast level indication; 1 (low) to 8 (high)
- ④ Push [ENT] to determine the brightness or push [CLR] to exit the Set-up menu.

## ■ MMSI check

Your ID code can be displayed via the set-up menu.

### • Check your ID

- ① Push [CALL], then push [▼] one or more times to select 'Set-up', then push [ENT].
- ② Select 'MMSI check', then push [ENT].
- ③ Your ID code shows on the display.
- ④ Push [CLR] to exit the Set-up menu.



# 5

## CONNECTION AND INSTALLATIONS

### ■ Connection diagram

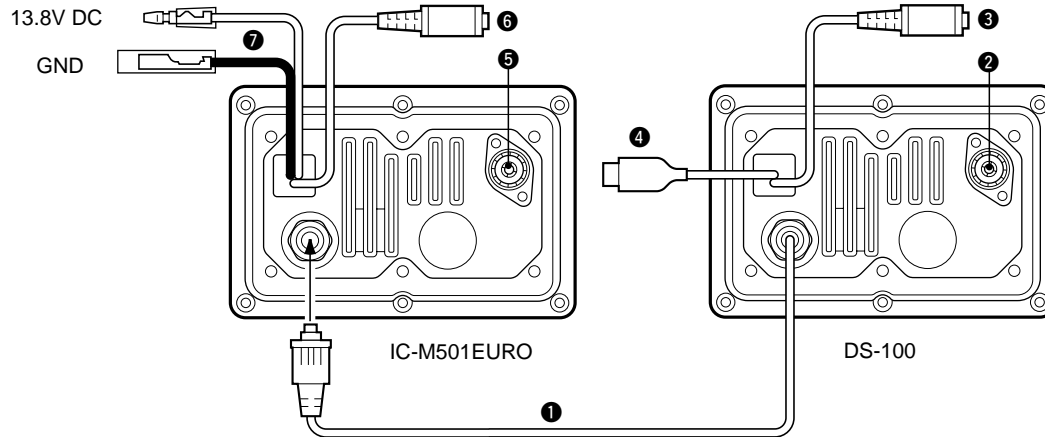

**NOTE:** Binding the GPS cable, GPS connector, clone receptacle, antenna connector with the water-resistant tape, increases the waterproofing of the controller.

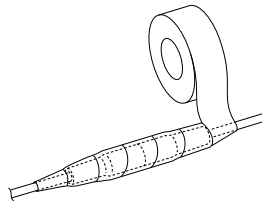



## ■ Rear panel description

### ① CONNECTION CABLE

Connects to the IC-M501EURO rear DSC controller receptacle.

### ② RECEIVE ANTENNA CONNECTOR

Connects a marine VHF receiving antenna with a PL-259 plug for emergency frequency signal receiving.

- Receiving frequency : 156.525 MHz
- Keep the emergency frequency signal receiving antenna away from the marine VHF antenna to avoid interference from the emitted RF signal.

### ③ CLONE RECEPTACLE

For dealer use only.

### ④ GPS RECEIVER CONNECTOR

Connects a GPS receiver (NMEA0183 ver.2.0) for sending position data without manual input.

### ⑤ ANTENNA CONNECTOR (IC-M501EURO)\*

Connects a marine VHF antenna with a PL-259 connector to the transceiver.

### ⑥ EXTERNAL SPEAKER RECEPTACLE (IC-M501EURO)\*

Connects to an external speaker.

### ⑦ DC POWER CONNECTOR (IC-M501EURO)\*

Connects the DC power cable supplied with IC-M501EURO, from this connector to an external 12 V DC power source.

\*Refer to the IC-M501EURO instruction manual.

## ■ Supplied accessories

① Knob bolt (2040 knob bolt) .....	2
② Mounting bracket (2345 Mobile bracket) .....	1
③ Spring washers (M 5 ) .....	2
④ Self-tapping screws (A05 x 20).....	2
⑤ Flat washers (M 5).....	2
⑥ Label (2349 CAUTION seal-R).....	1

## 5 CONNECTION AND INSTALLATIONS

### ■ Mounting

The universal mounting bracket supplied with your controller allows dashboard or overhead mounting. Please read the following instructions carefully.

- Mount the controller securely with bolts and nuts or it may come loose as a result of wave shocks or vibration.
- Mount the controller so that the face of the controller is at 90 degrees to your line of sight when operating it.

### CAUTION!

**KEEP** the controller at least 1 m away from your ship's magnetic navigation compass.

**CHECK** the installation angle; the function display may not be easy-to-read at some angles.

### • OVERHEAD MOUNTING

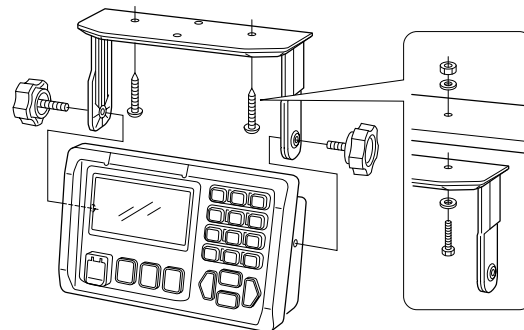

### • DASHBOARD MOUNTING (with optional MB-75):

For mounting the DS-100 to a dashboard panel.

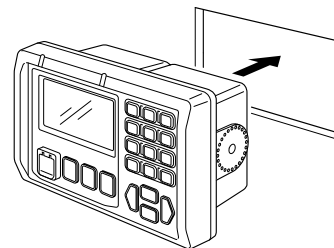

# VHF MARINE CHANNEL LIST

## ◇ International channels

CH	Frequency (MHz)		CH	Frequency (MHz)		CH	Frequency (MHz)		CH	Frequency (MHz)		CH	Frequency (MHz)		CH	Frequency (MHz)	
	Transmit	Receive		Transmit	Receive		Transmit	Receive		Transmit	Receive		Transmit	Receive		Transmit	Receive
01	156.050	160.650	11	156.550	156.550	21	157.050	161.650	62	156.125	160.725	72	156.625	156.625	84	157.225	161.825
02	156.100	160.700	12	156.600	156.600	22	157.100	161.700	63	156.175	160.775	73	156.675	156.675	85	157.275	161.875
03	156.150	160.750	13	156.650	156.650	23	157.150	161.750	64	156.225	160.825	74	156.725	156.725	86	157.325	161.925
04	156.200	160.800	14	156.700	156.700	24	157.200	161.800	65	156.275	160.875	77	156.875	156.875	87	157.375	161.975
05	156.250	160.850	15	156.750	156.750	25	157.250	161.850	66	156.325	160.925	78	156.925	161.525	88	157.425	162.025
06	156.300	156.300	16	156.800	156.800	26	157.300	161.900	67	156.375	156.375	79	156.975	161.575			
07	156.350	160.950	17	156.850	156.850	27	157.350	161.950	68	156.425	156.425	80	157.025	161.625			
08	156.400	156.400	18	156.900	161.500	28	157.400	162.000	69	156.475	156.475	81	157.075	161.675			
09	156.450	156.450	19	156.950	161.550	60	156.025	160.625	70	156.525	156.525	82	157.125	161.725			
10	156.500	156.500	20	157.000	161.600	61	156.075	160.675	71	156.575	156.575	83	157.175	161.775			

## ■ Specifications

### General

- Operating frequency : 156.525 MHz
  - Mode : 16K0G2B
  - Operating temperature range : -20°C to +60°C; -4°F to +140°F
  - Dimensions : 165(W) × 110(H) × 80(D) mm  
(projections not included) 6.5 (W) × 4.33(H) × 3.15(D) in
  - Weight : 1 Kg; 2.2 lb
  - Receive system : Double-conversion  
superheterodyne
  - Intermediate frequencies : 1st 21.70 MHz  
2nd 450 kHz
  - Sensitivity : -10 dB $\mu$  typ.
  - Intermodulation rejection ratio : More than 68 dB
  - Adjacent channel selectivity : More than 73 dB
  - Spurious response rejection ratio : More than 73 dB
- \*Measurement methods according to EN 301 025

## ■ Options

### MB-75 FLUSH MOUNT

For mounting the DS-100 to a panel.

# DIMENSIONS

8

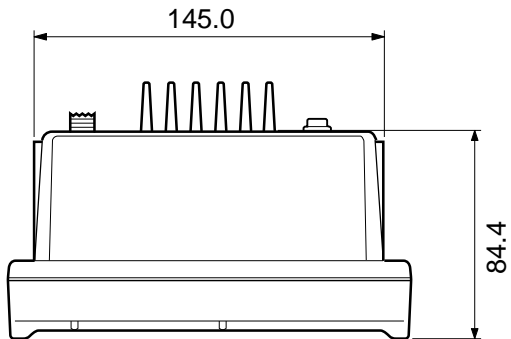
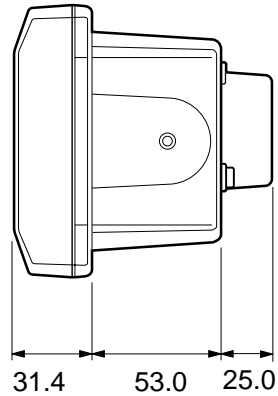
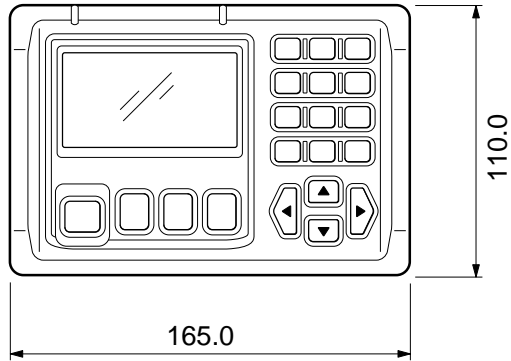

(Unit: mm)

## ■ MB-75 FLUSH MOUNT KIT

The MB-75 is used to mount the DS-100 DSC CONTROLLER flush to a flat surface such as an instrument panel.

### • Supplied accessories

Clamps .....1 sets

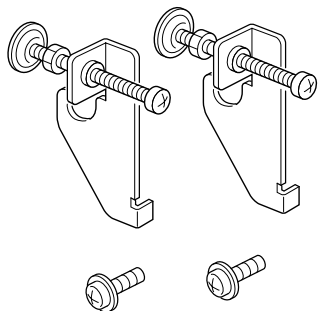

### • Instructions

- ① Using the template (p. 29), carefully cut a hole into the instrument panel (or wherever you plan to mount the controller) and slide the controller through the hole on the rear panel.

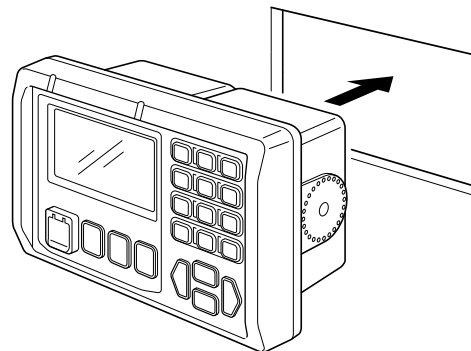

- ② Attach the 2 supplied bolts on either side of the DS-100 (See next page.)

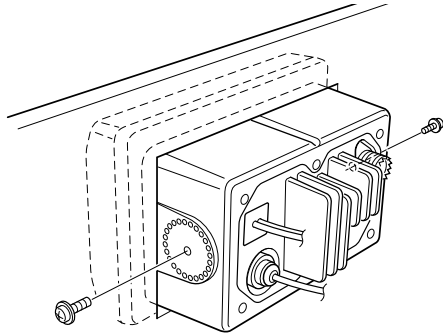

- ③ Attach the clamps on either side of the DS-100 as shown below.
- Make sure that the clamps align parallel to the DS-100's body.

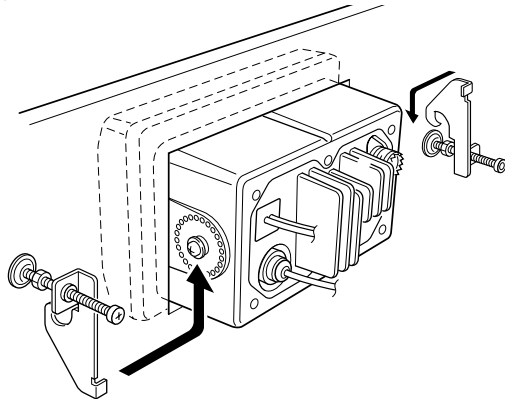

- ④ Tighten the end bolts on the clamps (rotate clockwise) so that the clamps press firmly against the inside of the instrument control panel.

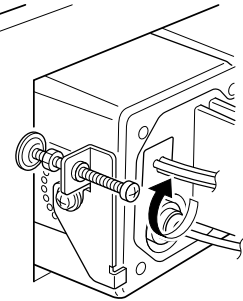

- ⑤ Tighten the locking nuts (rotate counterclockwise) so that the DS-100 is securely mounted in position as below.

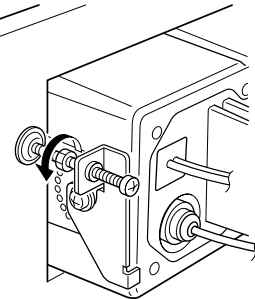

- ⑥ Connect the antenna and control cable, then return the instrument control panel to its original place.





# TEMPLATE 10

- Cut on the inside of the line.

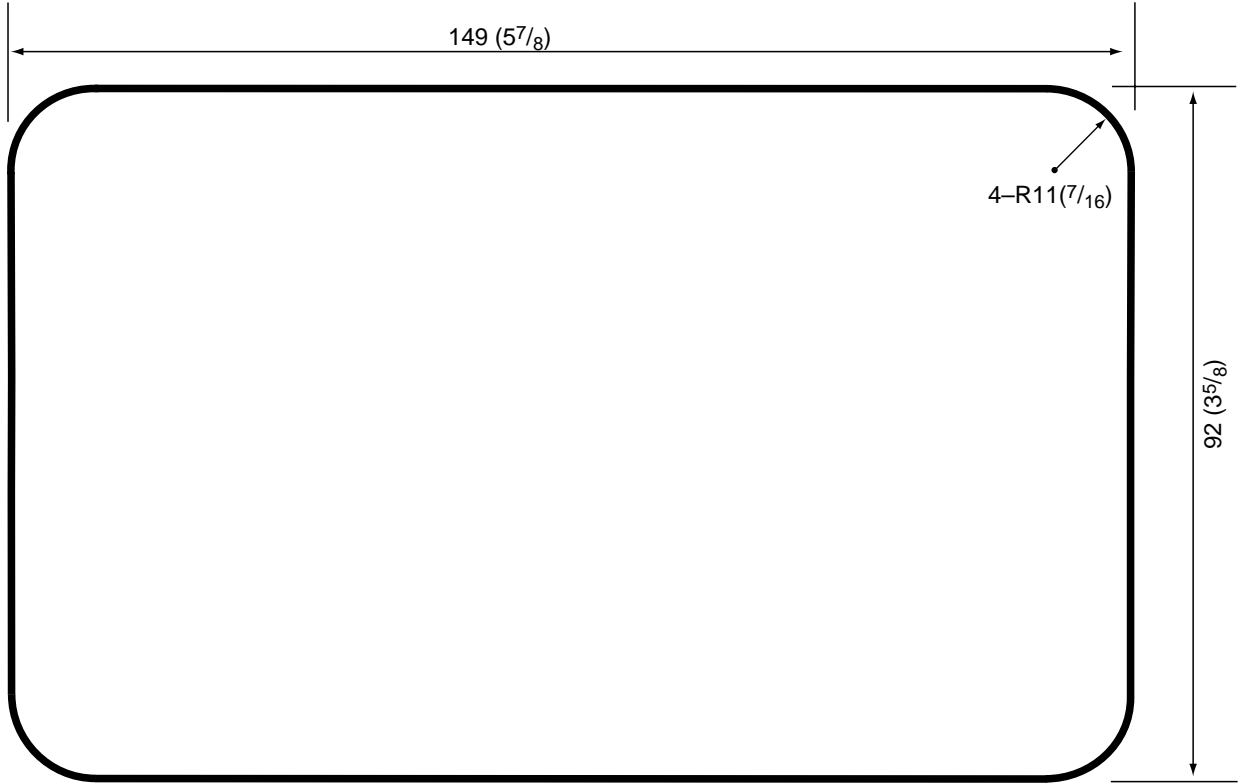

Cut here

Unit: mm (inch)





**DECLARATION  
OF CONFORMITY**

We Icom Inc. Japan  
1-1-32 Kamiminami, Hirano-ku  
Osaka 547-0003 Japan



Declare on our sole responsibility that this equipment complies the essential requirements of the Radio and Telecommunications Terminal Equipment Directive, 1999/5/EC, and that any applicable Essential Test Suite measurements have been performed.

Düsseldorf 11th Oct. 2000

Place and date of issue

**Kind of equipment:** DSC CONTROLLER

Icom (Europe) GmbH  
Himmelgeisterstraße 100  
D-40225 Düsseldorf

**Type-designation:** DS-100

Authorized representative name

**Version (where applicable):** \_\_\_\_\_

This compliance is based on conformity with the following harmonised standards, specifications or documents:

- i) EN 301 025-2 v 1.1.1 08/2000
- ii) EN 60945 1997
- iii) EN 60950 1992
- iv) \_\_\_\_\_
- v) \_\_\_\_\_

Icom (Europe) GmbH

T. Aoki  
General Manager

Signature

**Icom Inc.**

**Count on us!**

**< Intended Country of Use >**

■ GER	■ NED	■ ITA
■ AUT	■ BEL	■ GRE
■ GBR	■ LUX	■ SWE
■ IRL	■ ESP	■ DEN
■ FRA	■ POR	■ FIN